



List 9580

EXOPRO[®] PHX-PC-DFR, Pencil Neck, Deep Feed

SPEED FEED 1432-1433	CARBIDE	WXS	3 FLUTE	55°		SHANK h6	STUB	PACKED 1 PIECE
-------------------------	---------	-----	---------	-----	--	-------------	------	-------------------

Cutting Diameter Tolerance	
2mm ≤ D ≤ 12mm	+0 / -0.015mm

Radius Tolerance	
0.5 ≤ R ≤ 2	+/- 0.030mm



EDP Number	Diameter	Corner Radius	Length of Cut	Neck Length	Neck Diameter Min	Neck Diameter Max	Effective Draft Angle	Neck Draft Angle	Overall Length	Shank Diameter	Type	
												D (mm)
3097223	●	2.00	0.50	3.00	20.00	1.95	2.25	0.36	0.50	60.00	6.00	1
3097241	●	2.00	0.50	3.00	10.00	1.95	2.19	0.59	1.00	60.00	6.00	1
3097242	●	2.00	0.50	3.00	15.00	1.95	2.37	0.73	1.00	60.00	6.00	1
3097243	●	2.00	0.50	3.00	20.00	1.95	2.54	0.80	1.00	60.00	6.00	1
3097224	●	2.00	0.50	3.00	25.00	1.95	2.33	0.39	0.50	70.00	6.00	1
3097244	●	2.00	0.50	3.00	25.00	1.95	2.72	0.84	1.00	70.00	6.00	1
3097225	●	2.00	0.50	3.00	30.00	1.95	2.42	0.41	0.50	80.00	6.00	1
3097226	●	2.00	0.50	3.00	35.00	1.95	2.51	0.42	0.50	80.00	6.00	1
3097227	●	2.00	0.50	3.00	40.00	1.95	2.60	0.43	0.50	80.00	6.00	1
3097245	●	2.00	0.50	3.00	30.00	1.95	2.89	0.87	1.00	80.00	6.00	1
3097246	●	2.00	0.50	3.00	35.00	1.95	3.07	0.89	1.00	80.00	6.00	1
3097247	●	2.00	0.50	3.00	40.00	1.95	3.24	0.90	1.00	80.00	6.00	1
3097251	●	2.00	0.50	3.00	40.00	1.95	3.89	1.37	1.50	80.00	6.00	1
3097248	●	2.00	0.50	3.00	45.00	1.95	3.42	0.91	1.00	100.00	6.00	1
3097249	●	2.00	0.50	3.00	50.00	1.95	3.59	0.92	1.00	100.00	6.00	1
3097262	●	2.00	0.50	3.00	60.30	1.95	6.00	2.00	2.00	100.00	6.00	2
3097273	●	2.00	0.50	3.00	41.20	1.95	6.00	3.00	3.00	100.00	6.00	2
3097321	●	3.00	0.80	4.50	20.00	2.90	3.17	0.25	0.50	80.00	6.00	1
3097341	●	3.00	0.80	4.50	20.00	2.90	3.44	0.66	1.00	80.00	6.00	1
3097342	●	3.00	0.80	4.50	25.00	2.90	3.62	0.73	1.00	80.00	6.00	1
3097343	●	3.00	0.80	4.50	30.00	2.90	3.79	0.78	1.00	80.00	6.00	1
3097344	●	3.00	0.80	4.50	40.00	2.90	4.14	0.83	1.00	80.00	6.00	1
3097345	●	3.00	0.80	4.50	50.00	2.90	4.49	0.87	1.00	100.00	6.00	1
3097346	●	3.00	0.80	4.50	60.00	2.90	4.84	0.89	1.00	100.00	6.00	1
3097356	●	3.00	0.80	4.50	60.80	2.90	6.00	1.50	1.50	100.00	6.00	2
3097365	●	3.00	0.80	4.50	46.50	2.90	6.00	2.00	2.00	100.00	6.00	2
3097374	●	3.00	0.80	4.50	32.10	2.90	6.00	3.00	3.00	100.00	6.00	2
3097421	●	4.00	1.00	6.00	25.00	3.90	4.23	0.28	0.50	80.00	6.00	1
3097422	●	4.00	1.00	6.00	30.00	3.90	4.32	0.31	0.50	80.00	6.00	1
3097423	●	4.00	1.00	6.00	35.00	3.90	4.41	0.34	0.50	80.00	6.00	1
3097424	●	4.00	1.00	6.00	40.00	3.90	4.49	0.36	0.50	80.00	6.00	1
3097425	●	4.00	1.00	6.00	45.00	3.90	4.58	0.38	0.50	80.00	6.00	1
3097441	●	4.00	1.00	6.00	30.00	3.90	4.74	0.73	1.00	80.00	6.00	1
3097442	●	4.00	1.00	6.00	40.00	3.90	5.09	0.80	1.00	80.00	6.00	1
3097453	●	4.00	1.00	6.00	42.20	3.90	6.00	1.50	1.50	80.00	6.00	2
3097461	●	4.00	1.00	6.00	32.60	3.90	6.00	2.00	2.00	80.00	6.00	2
3097426	●	4.00	1.00	6.00	50.00	3.90	4.67	0.39	0.50	100.00	6.00	1
3097443	●	4.00	1.00	6.00	50.00	3.90	5.44	0.84	1.00	100.00	6.00	1
3097444	●	4.00	1.00	6.00	61.30	3.90	6.00	1.00	1.00	100.00	6.00	2
3097472	●	4.00	1.00	6.00	42.20	3.90	8.00	3.00	3.00	100.00	8.00	2
3097454	●	4.00	1.00	6.00	80.40	3.90	8.00	1.50	1.50	120.00	8.00	2
3097462	●	4.00	1.00	6.00	61.30	3.90	8.00	2.00	2.00	120.00	8.00	2
3097641	●	6.00	1.50	9.00	40.00	5.90	6.98	0.73	1.00	100.00	8.00	1
3097642	●	6.00	1.50	9.00	50.00	5.90	7.33	0.79	1.00	100.00	8.00	1
3097651	●	6.00	1.50	9.00	43.20	5.90	8.00	1.50	1.50	100.00	8.00	2
3097661	●	6.00	1.50	9.00	33.60	5.90	8.00	2.00	2.00	100.00	8.00	2
3097627	●	6.00	1.50	9.00	60.00	5.90	6.79	0.39	0.50	130.00	8.00	1
3097643	●	6.00	1.50	9.00	62.30	5.90	8.00	1.00	1.00	130.00	8.00	2
3097653	●	6.00	1.50	9.00	81.40	5.90	10.00	1.50	1.50	130.00	10.00	2
3097662	●	6.00	1.50	9.00	62.30	5.90	10.00	2.00	2.00	130.00	10.00	2
3097841	●	8.00	2.00	12.00	50.00	7.90	9.23	0.73	1.00	120.00	10.00	1
3097851	●	8.00	2.00	12.00	44.20	7.90	10.00	1.50	1.50	120.00	10.00	2
3097861	●	8.00	2.00	12.00	34.60	7.90	10.00	2.00	2.00	120.00	10.00	2

● Stocked ○ Available Upon Request; MOQ May Apply ▲ Globally Stocked



ABOUT OSG

DRILLING

THREADING

MILLING

HOLDERS

INDEX



List 9580 (Continued)

EXOPRO® PHX-PC-DFR, Pencil Neck, Deep Feed

SPEED FEED 1432-1433	CARBIDE	WXS	3 FLUTE	55°		SHANK h6	STUB	PACKED 1 PIECE
--------------------------------	----------------	------------	----------------	------------	--	--------------------	-------------	--------------------------

EDP Number		Diameter		Corner Radius	Length of Cut	Neck Length	Neck Diameter Min	Neck Diameter Max	Effective Draft Angle	Neck Draft Angle	Overall Length	Shank Diameter	Type
		D (mm)	R (mm)	Lc (mm)	L1 (mm)	d1 Min (mm)	d1 Max (mm)	α (°)	β (°)	L (mm)	d (mm)		
3097862	●	8.00	2.00	12.00	63.30	7.90	12.00	2.00	2.00	120.00	12.00	2	
3097826	●	8.00	2.00	12.00	80.00	7.90	9.09	0.40	0.50	150.00	10.00	1	
3097842	●	8.00	2.00	12.00	63.30	7.90	10.00	1.00	1.00	150.00	10.00	2	
3097853	●	8.00	2.00	12.00	82.40	7.90	12.00	1.50	1.50	150.00	12.00	2	
3097844	●	8.00	2.00	12.00	120.60	7.90	12.00	1.00	1.00	180.00	12.00	2	
3098041	●	10.00	2.00	15.00	64.30	9.90	12.00	1.00	1.00	120.00	12.00	2	
3098051	●	10.00	2.00	15.00	45.20	9.90	12.00	1.50	1.50	120.00	12.00	2	
3098061	●	10.00	2.00	15.00	35.60	9.90	12.00	2.00	2.00	120.00	12.00	2	
3098026	●	10.00	2.00	15.00	100.00	9.90	11.38	0.40	0.50	150.00	12.00	1	
3098042	●	10.00	2.00	15.00	80.00	9.90	12.17	0.80	1.00	160.00	16.00	1	
3098043	●	10.00	2.00	15.00	100.00	9.90	12.87	0.84	1.00	160.00	16.00	1	
3098044	●	10.00	2.00	15.00	120.00	9.90	13.57	0.87	1.00	180.00	16.00	1	
3098053	●	10.00	2.00	15.00	121.60	9.90	16.00	1.50	1.50	180.00	16.00	2	
3098045	●	10.00	2.00	15.00	140.00	9.90	14.26	0.88	1.00	200.00	16.00	1	
3098046	●	10.00	2.00	15.00	160.00	9.90	14.96	0.90	1.00	220.00	16.00	1	
3098064	●	10.00	2.00	15.00	92.90	9.90	16.00	2.00	2.00	220.00	16.00	2	
3098241	●	12.00	2.00	18.00	60.00	11.90	13.37	0.67	1.00	120.00	16.00	1	
3098224	●	12.00	2.00	18.00	120.00	11.90	13.68	0.41	0.50	180.00	16.00	1	
3098242	●	12.00	2.00	18.00	100.00	11.90	14.76	0.81	1.00	180.00	16.00	1	
3098243	●	12.00	2.00	18.00	122.60	11.90	16.00	1.00	1.00	180.00	16.00	2	
3098244	●	12.00	2.00	18.00	160.00	11.90	16.86	0.88	1.00	220.00	20.00	1	
3098254	●	12.00	2.00	18.00	160.80	11.90	20.00	1.50	1.50	220.00	20.00	2	

● Stocked ○ Available Upon Request; MOQ May Apply ▲ Globally Stocked

EP

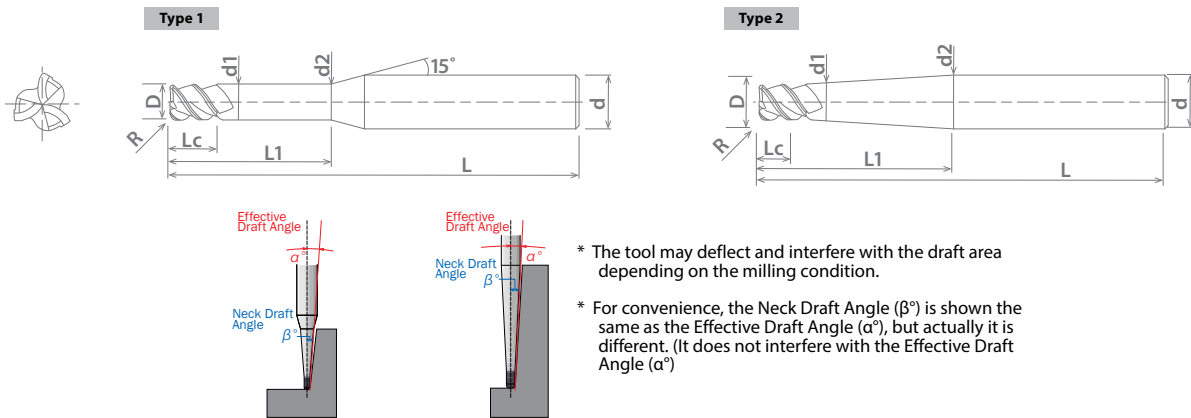

* The tool may deflect and interfere with the draft area depending on the milling condition.

* For convenience, the Neck Draft Angle (β) is shown the same as the Effective Draft Angle (α), but actually it is different. (It does not interfere with the Effective Draft Angle (α))

P					M			K	N		S		H						
Steel					Stainless Steel			Cast Iron	Non-Ferrous		HRSA		Hardened Steel						
Carbon Steel			Alloy Steel	Die Steel					Aluminum		Nickel Alloy	Titanium							
Low	Medium	High			300	400	17-4 PH		6061 7075	Casting			Inconel	6Al4V (30 HRC)	~35 HRC	35-45 HRC	45-50 HRC	50-70 HRC	
1010	1035	1045	1065	4140	4340														
○	○	○	○	○	○	○	○	○					○	○	○	○	○		

○ Good ○ Best

